

ROLLER TUBES TOP PLUS

INOMETA's TOP plus roller tube comes fully processed and ready-to-install, reduces your production costs and allows you to concentrate on your core business. INOMETA's high-quality TOP plus roller tube is based on the TOP roller tube. On the basis of either a precise specification or an individual customer drawing, we can do straightening, inside machining, inserting, smoothening, beveling, grinding and anodizing as needed.



DIAMETER

- 40 mm bis 200 mm

LENGTH

- 400 mm to 4.000 mm
- length tolerance up to 0,20 mm
- standard tolerance ISO h 10
- plane parallelism max. 0,05 mm

CONCENTRICITY

- straightened, concentric accuracy down to 0.15 mm/m

BORING

- acc. to individual specification
- single-stage: as shown
- multistage: acc. to customer's drawing
- quality of hole: e. g. ISO H7

GRINDING

- centerless grinding

SURFACE REFINEMENT

- anodizing
- hard-anodizing
- PROTEK®
- others on demand

Other dimensions as special design

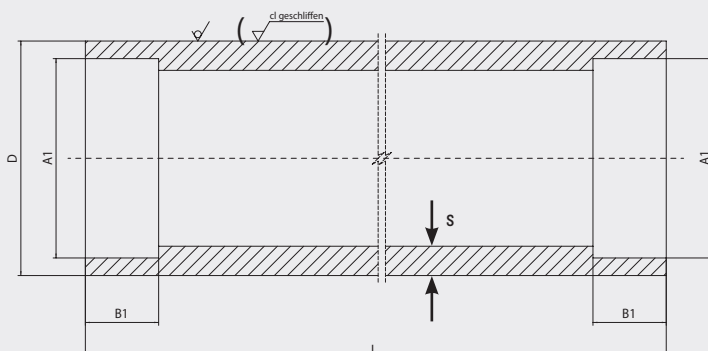

D = external diameter
s = wall thickness
L = length
A1 = bore diameter
B1 = bore depth
O = w/O = without
G = centerless grinding

Stand: 01/2018